

CV MY FIRST TRAMPOLINE AND ENCLOSURE

Assembly & User Instructions - Please keep for future reference

167/8314

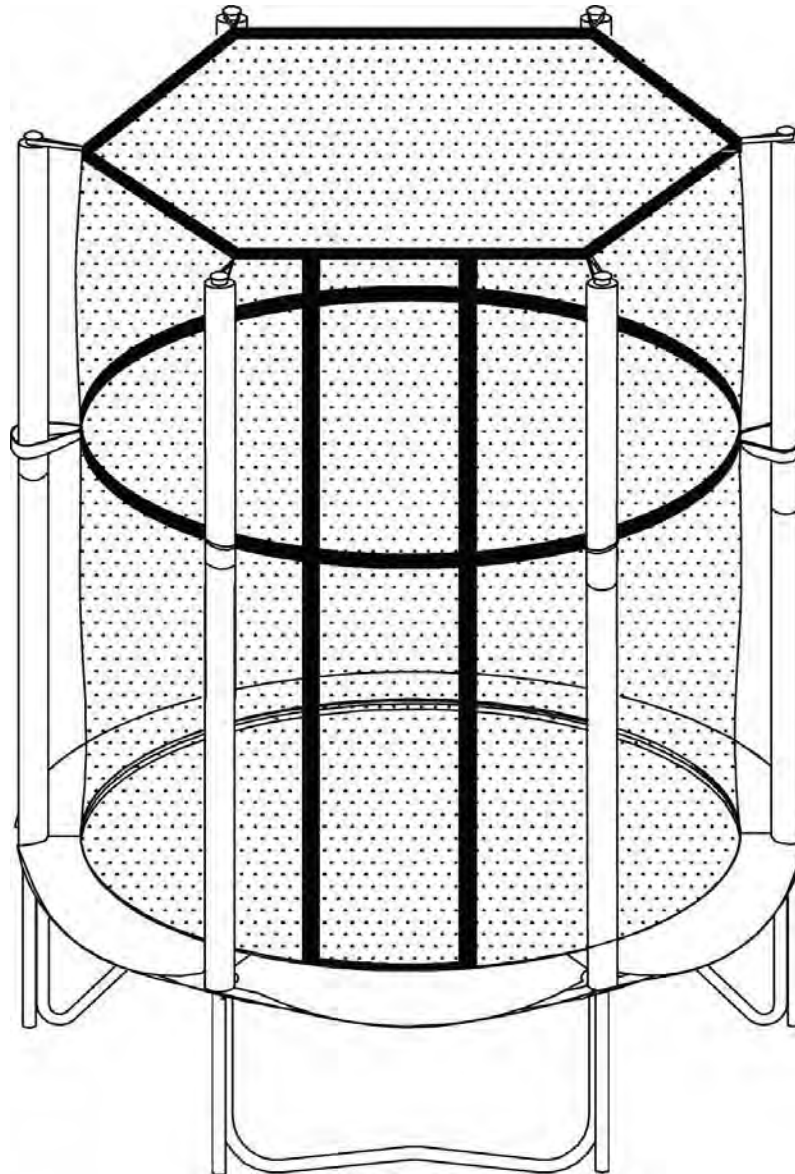

Assembly Size: Dia122 x H184cm

Important

Age: 3-6 yrs.
Maximum user
weight: 25 kg

**Tips: It will take 2 adults
around 30 minutes to
assemble.**

Important - Please read these instructions fully before assembly or use.

These instructions contain important information which will help you get the best from your product and ensure safe and correct assembly, use and maintenance.

If you need help or have damaged or missing parts, call the **Customer Helpline: (+44) 01702 208117**

Contents

WARNING

CAREFULLY READ AND UNDERSTAND ALL OF THE INSTRUCTIONS AND SAFETY WARNINGS IN THIS MANUAL BEFORE ASSEMBLING AND USING THIS PRODUCT. IT IS THE RESPONSIBILITY OF THE OWNER OF THIS TRAMPOLINE TO ENSURE THAT ALL USERS OF THIS PRODUCT ARE FULLY INFORMED ON THE PROPER SAFE USE AND THE INHERENT RISKS OF JUMPING ON A TRAMPOLINE. FAILURE TO DO SO CAN RESULT IN SERIOUS INJURY OR DEATH.

BEFORE YOU START TO ASSEMBLE

- Check the package and make sure you have all of the parts listed in the Parts List section of this user manual. IF ANY PARTS ARE MISSING, please call the Customer Service number listed on the cover page for assistance.
 - Do not install or use the product if any parts are missing or damaged. Store in a safe place until ready to install.
 - Make sure that you have plenty of space and a clean dry area suitable for the assembly of this trampoline.
- IT IS ESSENTIAL THAT THE INTENDED SITE FOR THIS TRAMPOLINE IS COMPLETELY FLAT AND LEVEL.**
- If the ground is uneven, this could cause movement in the frame and stress on the joined sections of the frame that could damage the trampoline and/or can cause serious injury.
- Two adults are needed to assemble this trampoline.
 - Heavy gloves must be used to protect your hands from pinch points during assembly and goggles must be worn to avoid injuries to the eyes.
 - Never modify the construction or the design of the product. Do not use any unauthorised non-Sportspower parts with this trampoline.
 - This pack may contain small parts and is not suitable for children under 3 years of age to be nearby during assembly.
 - **IMPORTANT:** Save this manual for future reference.

Safety Information	2-3
Parts	4
Assembly Instructions	5-12
Care and Maintenance	13

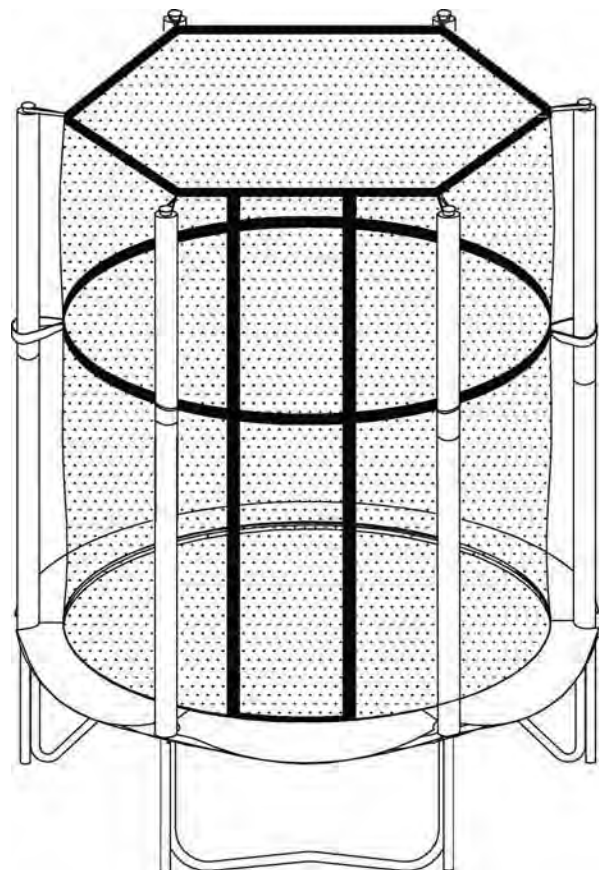



Safety Information

Important –Please read these instructions fully before assembling or use.



WARNING

READ ALL INSTRUCTIONS BEFORE ASSEMBLING OR USING THIS EQUIPMENT

- This product is intended for OUTDOOR USE.
- This trampoline must only be used under constant adult supervision.
- This trampoline is intended for use by children aged between 3 to 6 years.
- The trampoline must only be used by one child at a time and the maximum weight should not exceed 25 kg.
- This product is for household and family domestic use only. It is not for use in schools, playgrounds, rental or commercial use.
- Ensure that the trampoline enclosure has been assembled correctly, as per the instructions in this manual and that the opening is fully closed before use.
- Do not use the trampoline when under the influence of alcohol, drugs or medication, which may impair the jumper's judgement.
- Always consult your physician before performing any kind of physical activity.
- Do not use the trampoline if you have high blood pressure.
- Do not use the trampoline if you have a medical history of neck or back injuries or mental or physical conditions that could cause injury.
- Do not use if the user has any broken bones (casts) or has recently been in the hospital for extensive treatments (operations, severe wounds, stitches, back injury or concussion).
- Do not use without the consent of your physician, if pregnant.
- Do not use the trampoline during windy conditions or if the user or the trampoline surface is wet. These conditions can cause the user to lose control and fall resulting in serious injury.
- Warning. Empty pockets and hands before jumping.
- Warning. Do not eat while jumping.
- Warning. Do not exit by a jump.
- The trampoline should not be buried or sunken into the ground.

SAFE PLAY CONDITIONS:

- Always use the product in a well-lit area. Do not use without lighting during dawn, dusk or in complete darkness!
- The trampoline must be placed on a surface that is COMPLETELY FLAT AND LEVEL. If the ground is uneven, this could cause movement in the frame and could cause stress on the joined sections of the frame that could damage the trampoline and/or can cause serious injury.
- DO NOT install or position this trampoline on a hard surface such as concrete, tarmac or paving. Suitable surfaces are grass, sand or a play area covered with an appropriate depth of play bark material.

- Maintain clear space on all sides of the product. Make sure that there are no hazardous objects above, below or near the trampoline. Such objects include walls, fences, tree limbs/trunks, electrical power wiring, rocks, sprinkler heads or other recreational objects (i.e. swing sets, swimming pools). Children can be seriously injured by colliding with such obstacles.
- Adequate overhead clearance is essential. A minimum of 3 meter from ground level is recommended. Provide clearance for wires, tree limbs, and other possible hazards.
- Do not use the trampoline indoors, as this product is intended for outdoor home use only.
- During winter period, the snow load and the very low temperature can damage the trampoline. It is recommended to remove the snow and store the mat and the enclosure indoor.
- Wind can cause the trampoline to be lifted off the ground and become airborne. This can present a danger to individuals and to property. We recommend consulting a local licensed contractor to best determine how the anchor system should be constructed for your specific conditions. Even with anchors, a trampoline can be lifted, just like anything else, by strong winds. If the winds are anticipated to be very strong, the trampoline should be disassembled and stored away safely until the weather conditions improve. Damage from the wind or other severe weather is not covered by the manufacturer's warranty.

SAFE USE CONDITIONS:

- Children must always be supervised while they are playing on the trampoline and must be instructed not to use the trampoline in an inappropriate or hazardous manner. Take precautions to prevent access to the trampoline by children when there is no adult supervision.
- Restrict access to the trampoline by any unauthorized users without your consent.
- Trampolines are rebounding devices, which propel the user to unaccustomed heights, and into a variety of body movements. Rebounding off of the trampoline, striking the frame or springs, or improperly landing on the trampoline mat may cause serious injury.
- Always start and maintain your jump at the center of the trampoline mat in order to reduce the risk of landing on the frame or springs or falling off the trampoline.
- Avoid bouncing too high. Stay low until you can control your bounce and land consistently in the middle of the trampoline mat.
- Ensure the trampoline frame and springs are fully covered by the safety pad to avoid any direct contact with metal parts.



Safety Information

Important –Please read these instructions fully before assembly or use.

- The trampoline is several feet off the ground. Jumping off the trampoline to the ground or any other surface may result in injury. Smaller children may need assistance getting up onto or down from the trampoline. Mounting and dismounting properly should be followed as a strict rule. Users should climb onto the trampoline by placing their hands on the frame and stepping or rolling up onto the frame, across the bungee cords and onto the mat. Do not step directly on the frame pad or grasp the frame pad when mounting or dismounting the trampoline. To dismount, jumpers should walk to the side of the mat, bend over and place their hands on the frame, then step from the mat to the ground. Users should always place their hands on the frame while mounting or dismounting.
- Do NOT use the trampoline as a springboard to jump onto other objects.
- Remove all objects not designed for use with the trampoline from the trampoline before use. Do not let children take toys or other items onto the trampoline.
- Do not jump or step onto the frame pad as it was not designed to support the weight of a person.
- Do not use the trampoline while holding or wearing any type of sharp or pointed objects such as jewelry, watches, rings, eyewear and necklaces before using this product. This will prevent the jewelry from tearing the mat or getting caught in the safety netting.
- Do not wear loose fitting clothing that may catch or snag during play.
- Never wear footwear (e.g. shoes) when using the trampoline.
- Always tie back long hair so that it does not block user's vision or get caught in the safety netting.
- **FRAME PADS** – Frame pads are there to protect user from any fall or landing on the bungee cords and frame. On no account should people be permitted to sit or stand on them when the trampoline is in use. You should also make sure that smaller users do not use the inside edges of the pads as a "handle" when getting up on to the trampoline.
- Never use the trampoline without the frame pad being securely attached. Properly tie down the frame pad before each use. Improper assembly of the frame pad may lead to injury!
- Always check to ensure there are no obstructions or objects under the trampoline. Also check that there are no pets or other people underneath the trampoline.
- Do not jump on the trampoline with a snowboard, skateboard, roller blades, bicycle or any other equipment.
- DO NOT hold any foreign objects not authorized by the manufacturer in your hand.
- DO NOT place any objects on the trampoline while anyone is jumping on it. Please be aware of your surroundings to ensure there are no objects that could cause harm when you are playing on the trampoline.
- The frame of your trampoline is made of steel and it will conduct electricity. No electrical equipment (lights, heaters, extension cords, household appliances, etc.) should be permitted in or on the enclosure under any circumstances to avoid the risk of electrocution.

ENCLOSURE NETTING AND MAT – SAFE USE CONDITIONS

- Children **MUST NEVER** be left unattended inside the enclosure at any time.
- The enclosure is **ONLY** intended to be used to reduce the risk of injury from falling off the trampoline. Do not intentionally kick, bounce against, climb on, hang from, jump over or crawl under the netting.
- Enter and exit the enclosure only through the enclosure door. Do not go through the gap between the netting and the mat. Trying to exit this way poses a risk of strangulation, especially for young children.
- The enclosure netting and mat must be inspected prior to each use. If there are any signs of weakness, you must stop using the trampoline immediately, properly store the trampoline and restrict access by users until a new Sportspower authorized replacement netting or pad is installed
- It is recommended that you replace the trampoline enclosure net and pad every 12 months.

Parts

If you have damaged or missing parts,
call the **Customer Helpline: (+44) 01702 208117**

Please Check you have all the parts fittings listed below.

Note: The following lists the quantity of hardware needed to assemble this product.
In some cases, more fittings may be supplied than are required.



1 Top Rail with Leg Sockets x 6



2 Leg Base x 3



3 clamp parts x 6



4 Leg Base x 6

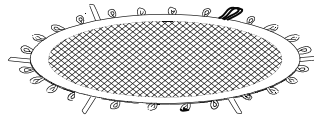

5 Trampoline Mat x 1

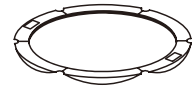

6 Frame Pad x 1

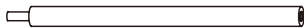

7 Lower frame tube with Foam x 6



8 Upper Frame Tube with Foam x 6

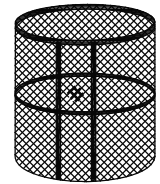

9 Enclosure Netting x 1

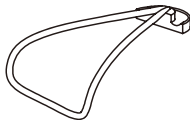



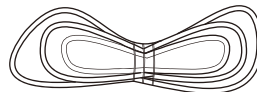



10 Bungee Cord x 30 + 2 (spare)

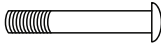

11 Cord x 1

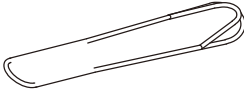
Note: The quantities below are the correct amount to complete the assembly. In some cases more fittings may be supplied than are required.

<p>A</p>  <p>Bolt x12 (M6x68mm)</p>	<p>B</p>  <p>Flat Washer x24 (Ø13xØ6.5mm)</p>	<p>C</p>  <p>Arc Washer x12 (M6)</p>	<p>D</p>  <p>Cap Nut x12 (M6)</p>
<p>E</p>  <p>Wrench x1 (10mm)</p>	<p>F</p>  <p>Tool x1</p>	<p>G</p>  <p>x1 (4mm)</p>	

Ruler - Use this ruler to help correctly identify the bolts/screws

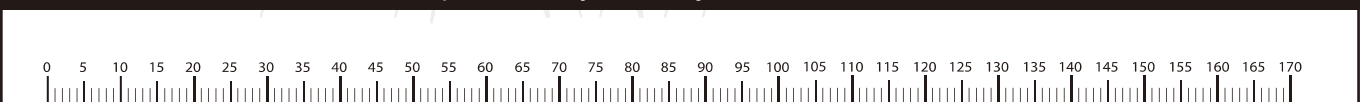

Assembly Instructions

Step 1

CONNECT 1 TOGETHER AS SHOWN

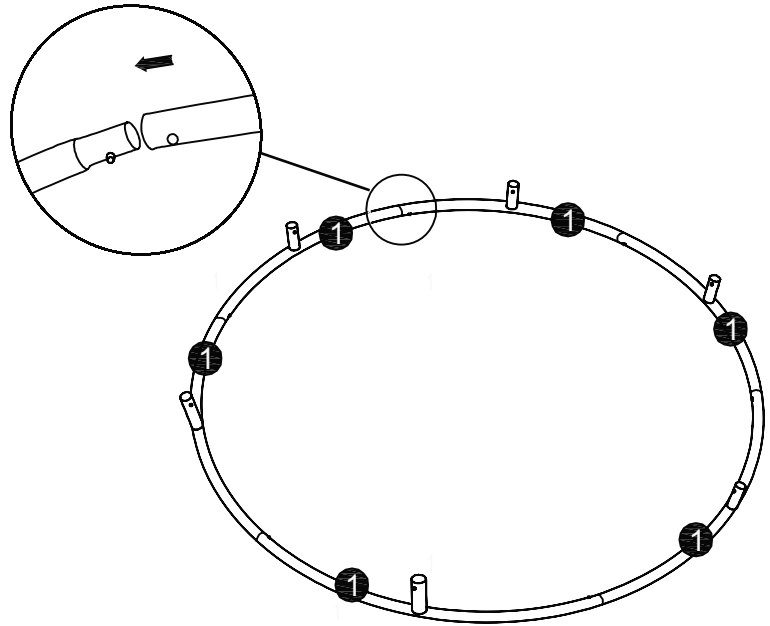

Step 2

INSERT 2 INTO THE SOCKETS OF 1. MAKE SURE THE RETRACTABLE BUTTON ON 2 IS SECURED INTO THE HOLE ON 1.

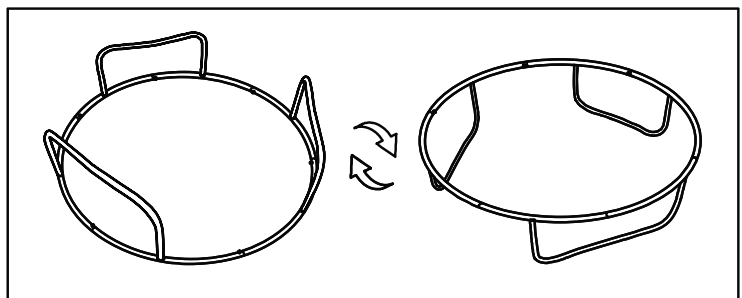
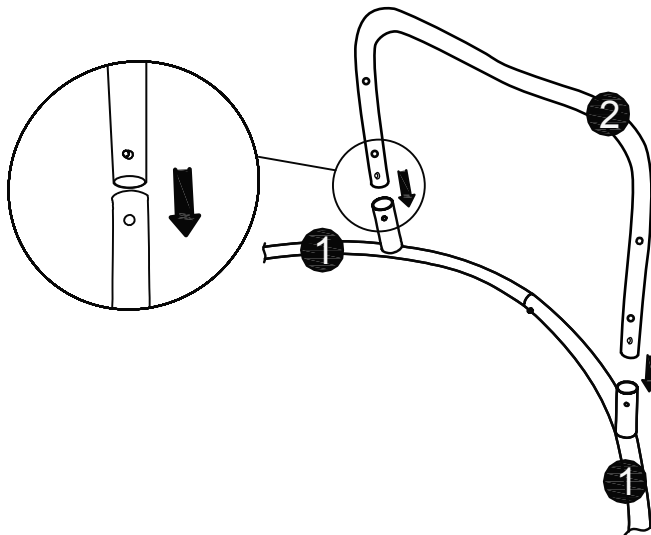

Assembly Instructions

Step 3

TURN OVER THE TRAMPOLINE FRAME AND CONNECT 3 AND 4 TO ALL LEGS USING A,B,C,D AS SHOWN.

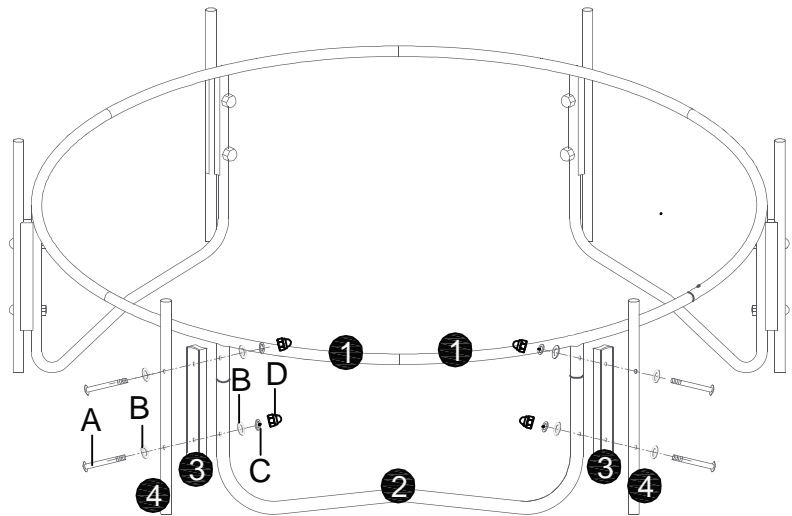

x12	x24	x12	x12
A	B	C	D

Step 4

PLACE THE MAT ON THE GROUND IN THE CENTER OF THE ASSEMBLED FRAME.

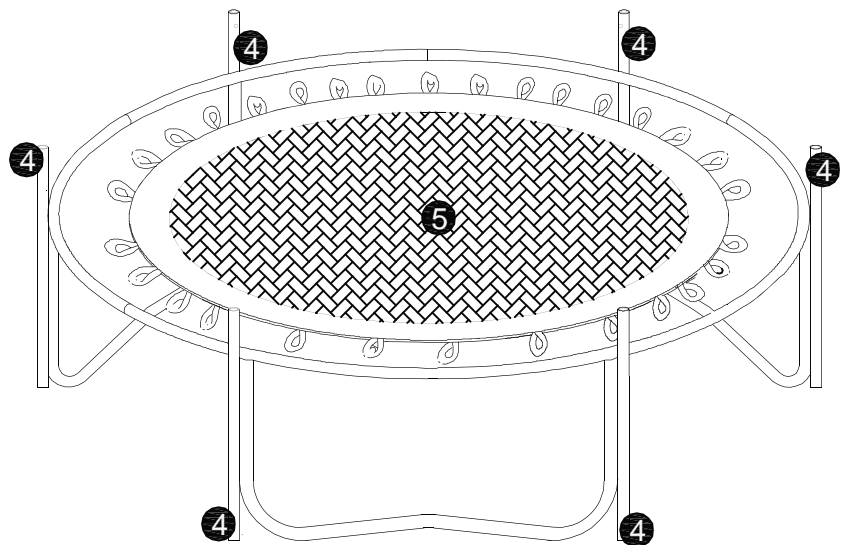

Assembly Instructions

Step 5

CONNECT THE MAT TO THE FRAME WITH THE BUNGEE CORDS (10). AS SHOWN IN THE ENLARGED DIAGRAM, STRAND THE BUNGEE CORD THROUGH THE LOOP ON THE MAT AND USE THE TOOL PROVIDED (F) TO PULL IT ALL THE WAY AROUND THE FRAME AND LATCH IT OVER THE PLASTIC CAP. MAKE SURE ALL BUNGEE CORDS ARE SECURELY IN PLACE.

IMPORTANT:
INSTALL BUNGEE CORDS IN AN ALTERNATING MANNER ON OPPOSITE SIDES OF THE TRAMPOLINE SO THE TENSION IS EVENLY DISTRIBUTED. FAILURE TO DO THIS WILL CAUSE THE TRAMPOLINE TO BE UNEVEN.

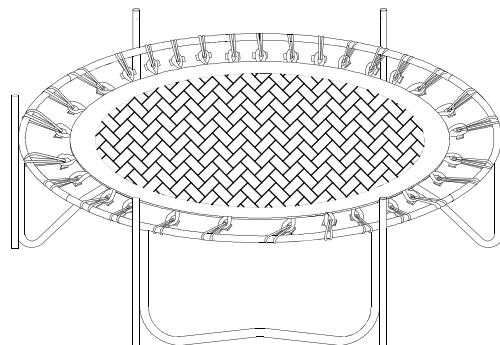
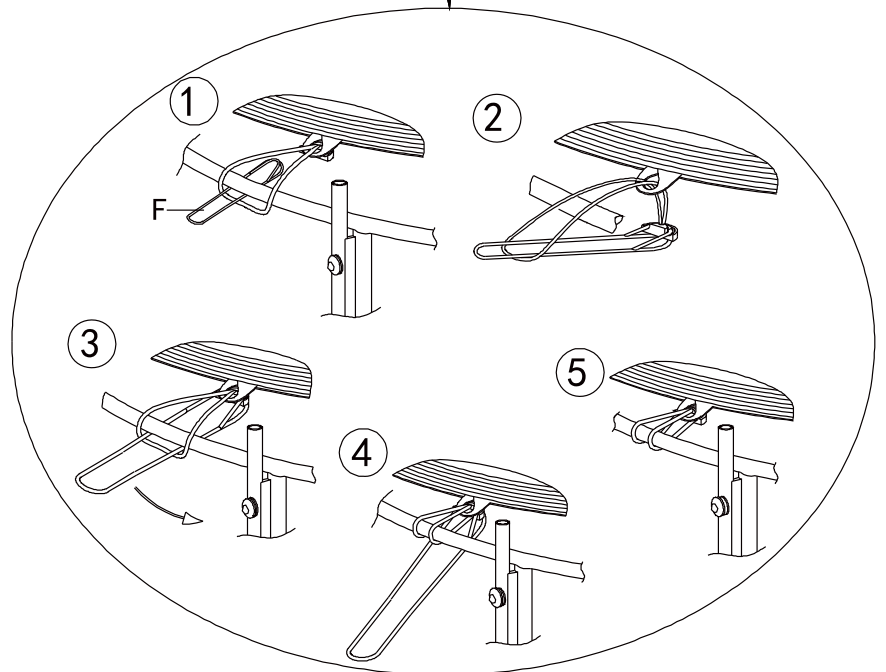
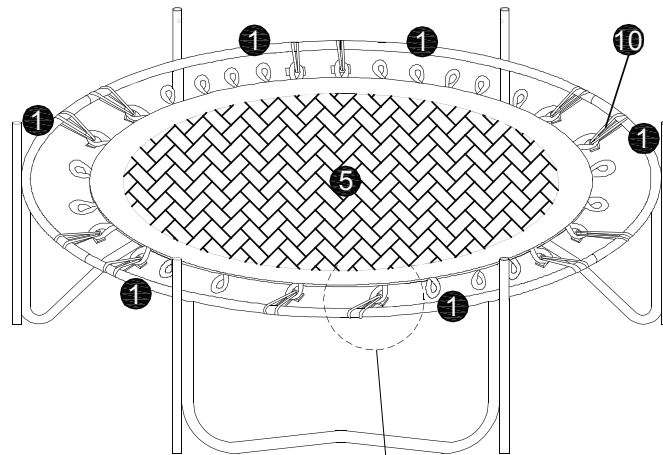

Assembly Instructions

Step 6

COVER THE TRAMPOLINE FRAME WITH THE FRAME PAD. MAKE SURE ALL METAL PARTS ARE COVERED. TIE ALL ELASTIC STRAPS ON THE PAD TO THE FRAME AS SHOWN IN THE ENLARGED DIAGRAM.

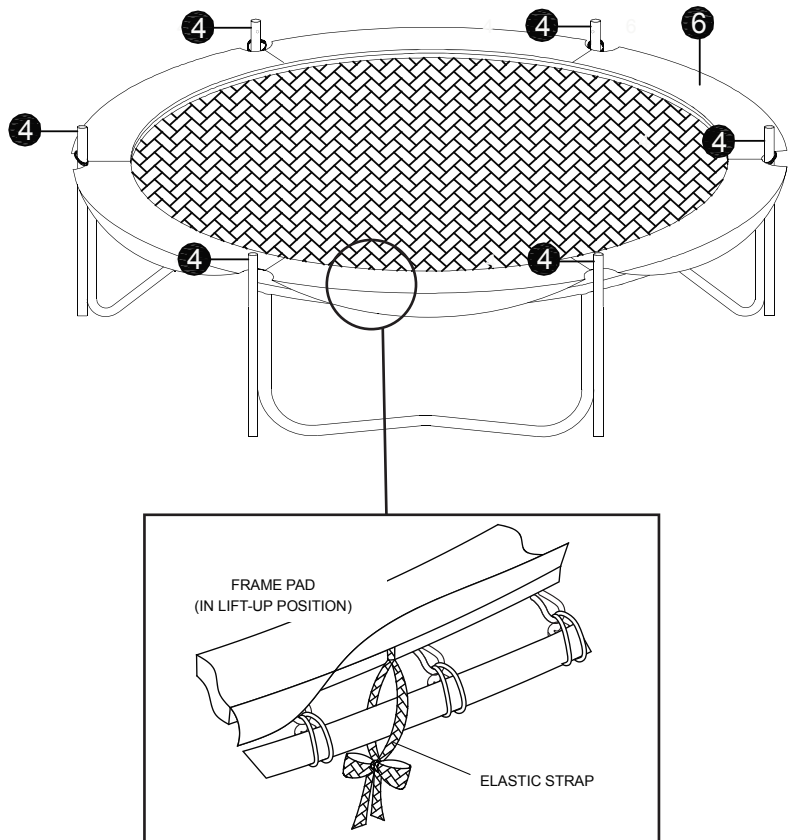

Step 7

CONNECT SIX LOWER FRAME TUBE WITH FOAM(7) TO THE TRAMPOLINE FRAME AS SHOWN.

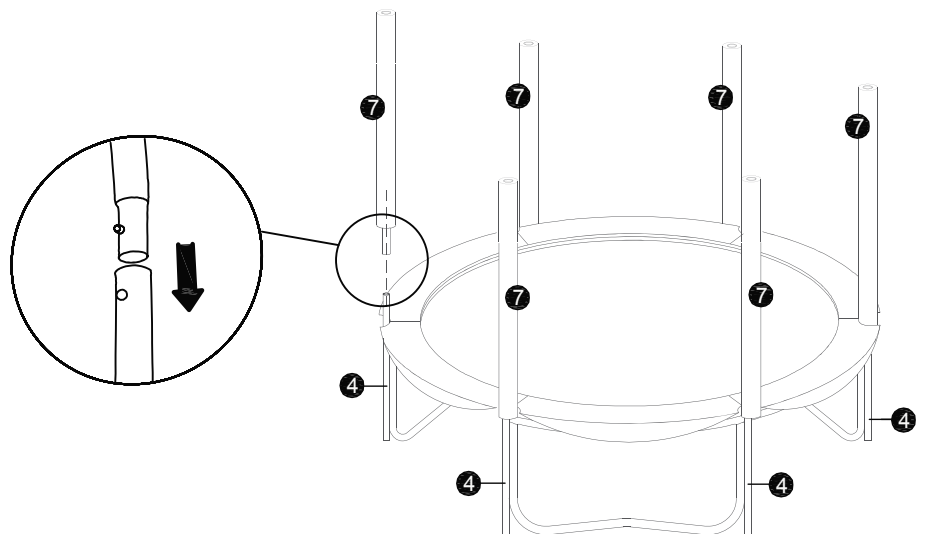

Assembly Instructions

Step 8

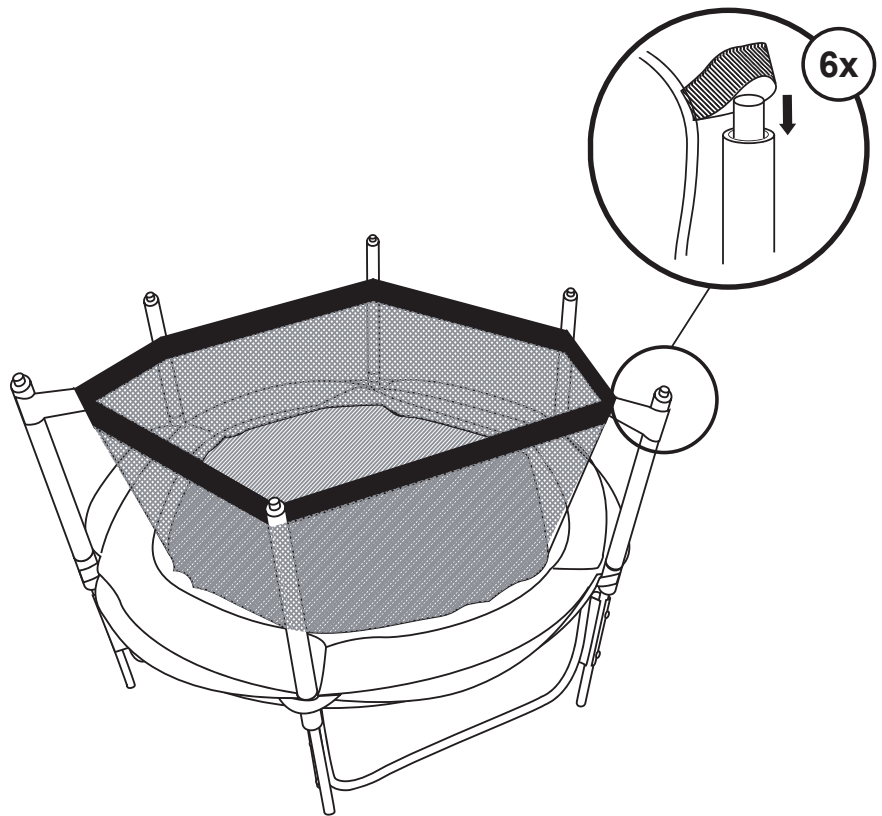

Step 9

CONNECT SIX UPPER
FRAME TUBE WITH FOAM(8)
TO THE TRAMPOLINE
FRAME AS SHOWN.

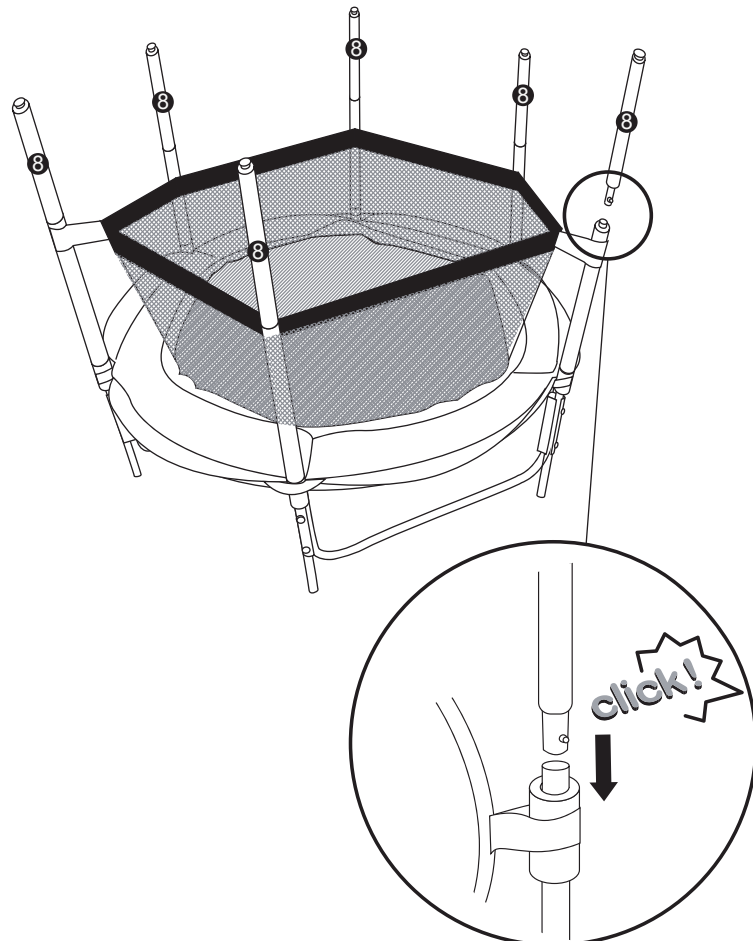

Assembly Instructions

Step 10

ATTACH THE ENCLOSURE NET AS SHOWN.

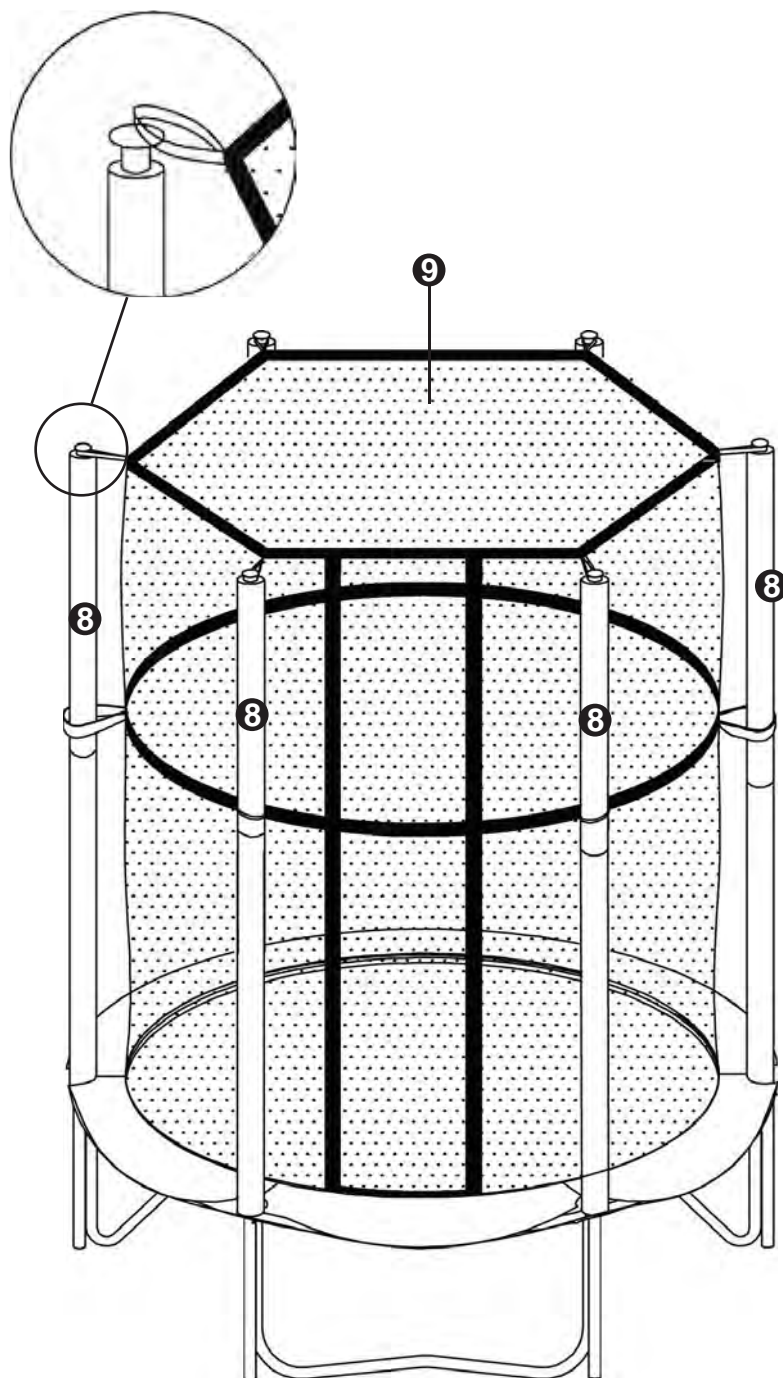

Assembly Instructions

Step 11

FASTEN THE BOTTOM OF THE ENCLOSURE NET TO THE TRAMPOLINE FRAME BY THREADING THE CORD THROUGH THE MAT AND THE NET AS SHOWN IN THE ENLARGED DIAGRAM.

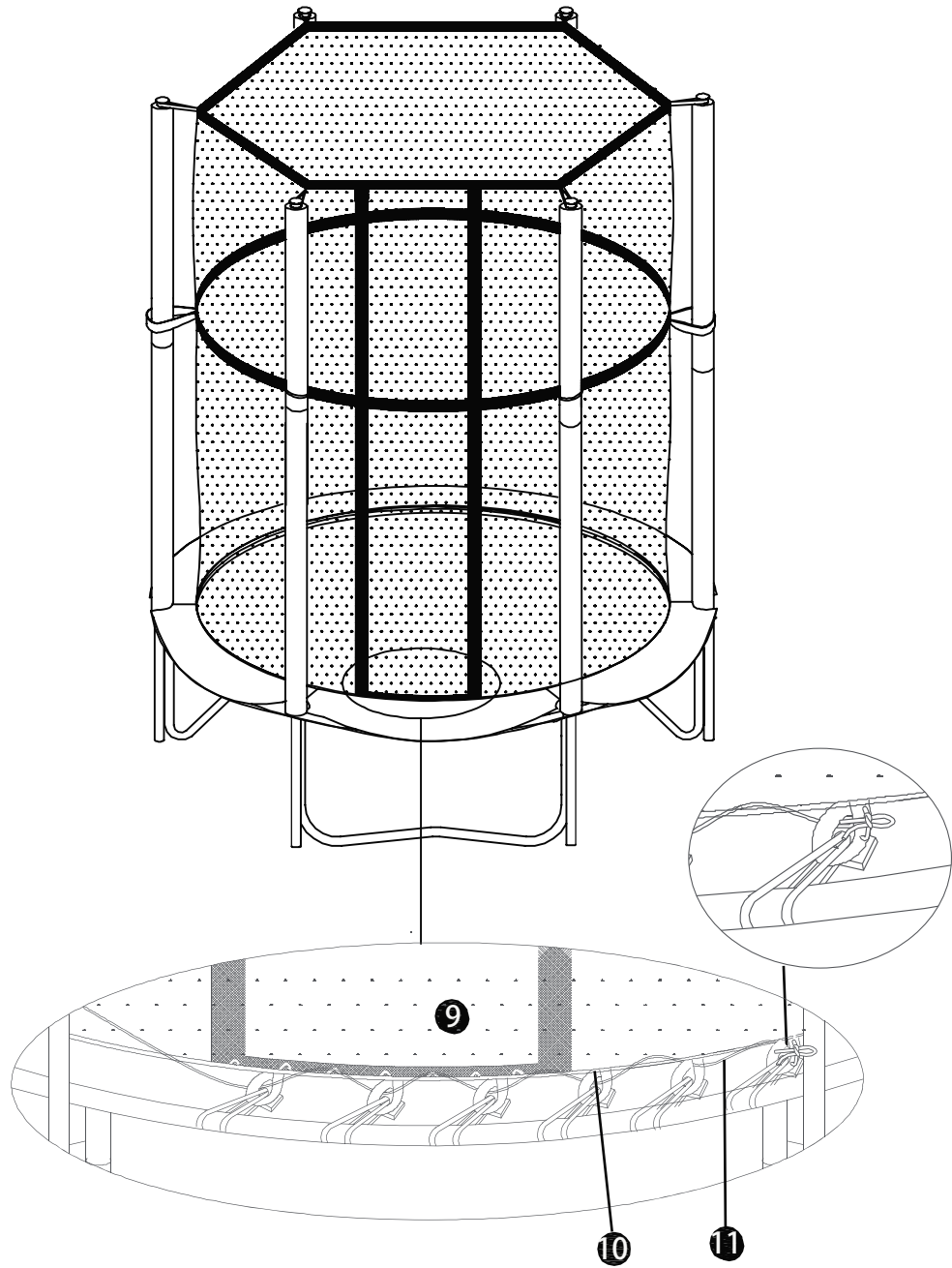

Assembly Instructions

Step 12

FASTENED THE VELCRO OF SAFETY ENCLOSURE NET DURING USE.

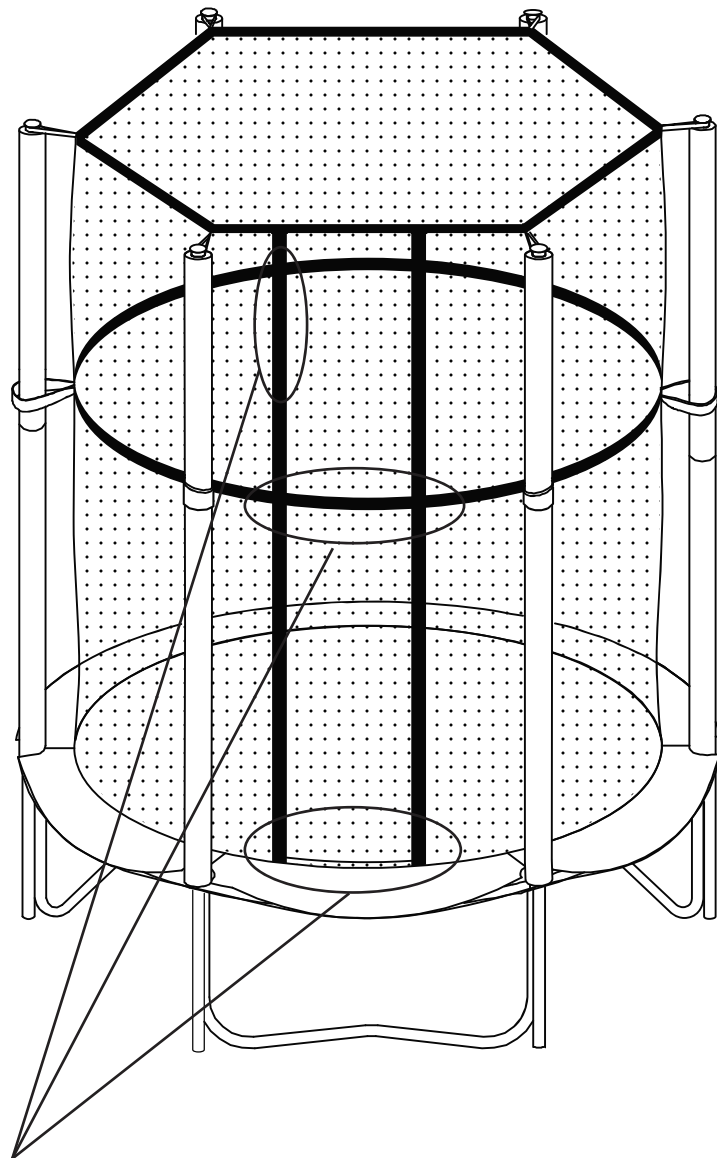

FASTENED THE VELCRO

Care and Maintenance

General

This Trampoline was designed and manufactured with quality materials and craftsmanship.

If correct care and maintenance is provided, it will provide users with years of exercise, fun and enjoyment.

Inspect regularly for:

- CHECK ALL NUTS AND BOLTS TWICE MONTHLY DURING THE USAGE SEASON FOR TIGHTNESS AND TIGHTEN AS REQUIRED. IT IS PARTICULARLY IMPORTANT THAT THIS PROCEDURE BE FOLLOWED AT THE BEGINNING OF EACH SEASON.
- Never use pliers to tighten up screws –these can cause damage to both the paintwork and the special anti-corrosion plating.
- Tighten all nuts and bolts securely. Replace as needed. If not checked regularly, bolts can be loose or missed and components can become detached and cause injuries.
- Check the unit at the beginning of the usage season and monthly thereafter for evidence of deterioration.
- Immediately remove and replace any items that appear to be weak or broken. Contact Customer Support for replacement parts.
- Check all covers designed for bolts and sharp edges regularly to be certain they are present and in good condition. Replace as needed. It is particularly important that all covers are checked prior to the first use each season.
- Inspect handle bar, hardware, and etc., for proper closure and for signs of wear, deterioration, rust and/or damage. Replace as needed.
- In windy conditions
It is important that you secure your trampoline during windy conditions. Move the trampoline to sheltered area, secure the frame by the rim to the ground or, in extreme conditions, disassemble and store in a dry safe place.
- Moving the trampoline
Care should be taken when moving the trampoline. It should be lifted by at least 2 people. Do not drag the trampoline.
- Inspect the trampoline before each use and replace any worn, defective or missing parts. The following conditions could represent potential hazards:
 - Holes and tears in the mat.
 - Sagging mat.
 - Loose stitching or deterioration to the mat.
 - Bent or broken frame parts.
 - Broken, damaged or missing springs.
 - Sharp protrusions of any kind on frame, spring or the mat.
- When the time comes to disassemble and dispose of this product, please completely disassemble the unit and discard of it in a safe place and manner so as not to present any hazard to any individual. It is important to check and maintain the main parts at regular intervals. If these checks are not carried out, the toy could overturn or otherwise become a hazard.
- Whenever practical, the instructions shall also be affixed to the toy.
- **IMPORTANT!KEEP FOR FUTURE REFERENCE.**

WARNING!

Not suitable for children under 36 months. Choking hazard. For outdoor use only. This equipment is intended for domestic family use for outdoors only. This Trampoline is for children 3-6 years and the maximum weight of each user must not exceed 25 kg. To be played in an open area with adult supervision. Packaging materials are not toys. Please remove all packaging and packing tags/wires before giving this toy to your child. Maintenance to be carried out under the direct supervision of a responsible adult. Colour, designs and decorations may vary from those shown in the photographs.



WARNING! Not suitable for children under 3 years due to small parts, choking hazard.



If you need help or have damaged or missing parts, call the Customer Helpline: (+44) 01702 208117
Produced for Chad Valley Toys. Argos Ltd. Country of origin: China
Address: 489 - 499 Avebury Boulevard, Central Milton Keynes, MK9 2NW. www.argos.co.uk