

# TODDLER TRAMPOLINE

Assembly, Installation, Care, Maintenance, and User Instructions

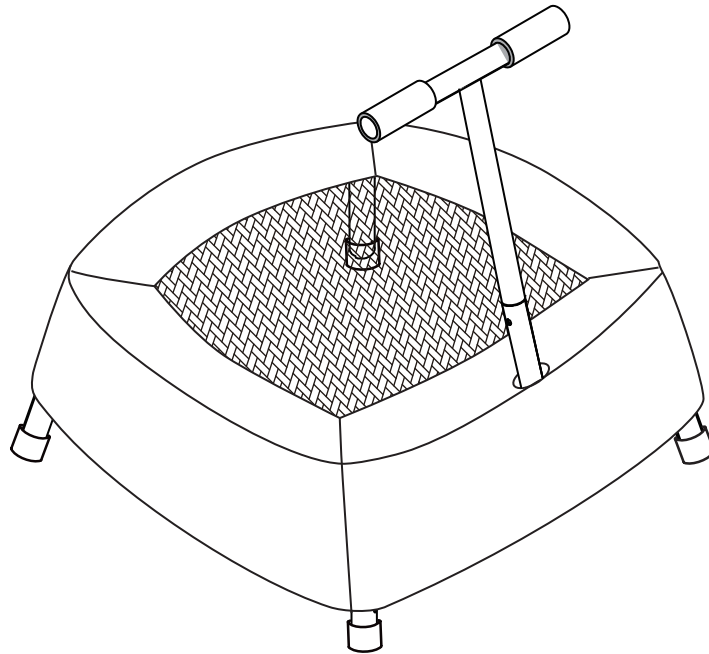

Assembly Size: 58 x 58 x 62.5cm

## **⚠ DANGER**

- DO NOT attempt somersaults or flips. Paralysis or death can result if you land on your head or neck!
- No more than one person on the trampoline at a time. Multiple users increase the risk of injury.
- Use trampoline only with mature, knowledgeable supervision.

## **⚠ WARNING**

- **These instructions are important to minimize chances of injury. Please read them thoroughly before you assemble and use this trampoline. Retain this manual for future reference.**
- Maximum weight of the user shall NOT exceed 45lbs/20kg for this product.
- This product is intended for children between ages 18 to 36 months.
- Do not allow children under 3 years old nearby during assembly. Small parts – choking hazard!
- Estimated assembly time: 2 adults, 1 hour.
- Domestic and outdoor use only.
- Constant adult supervision required.
- Save this manual for future reference.
- Empty pockets and hands before jumping.
- Only one user. Collision hazard!

**DO NOT RETURN PRODUCT TO THE STORE. FOR CUSTOMER SERVICE OR REPLACEMENT PARTS, PLEASE Call (+44) 0330 0904 420, Email [warranty@sportspower.biz](mailto:warranty@sportspower.biz)**

# DANGER



**NO SOMERSAULTS OR FLIPS – PARALYSIS OR DEATH** can result if you land on your head or neck!



No more than **ONE** user at a time (maximum weight - 45 lbs/20 kg).



Do not use if in a cast or have previous leg, arm, head, neck or back injury.



**Warning! Not suitable for children under 18 months. Small parts. Choking hazard.**



Remove all hard or sharp objects including jewelry, eyeglasses, sunglasses or hairclips before jumping.



Do not use without the consent of your physician, if pregnant.

## Daily Pre-Inspection:

- Inspect legs for proper attachment or cracks
- Inspect mat for tears or worn stitching
- Inspect frame for sagging or cracks

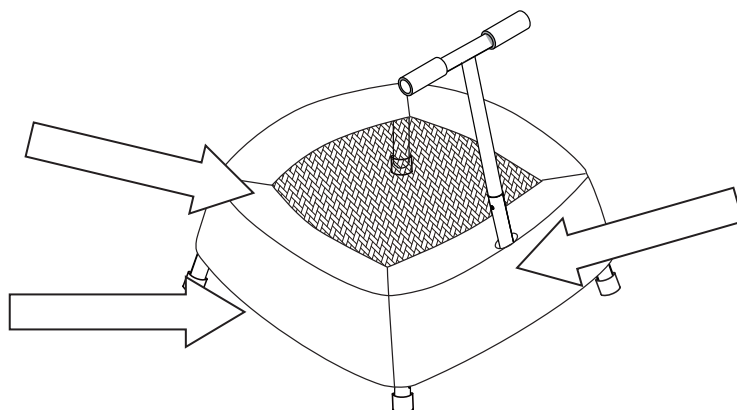



- Use trampoline only with mature, knowledgeable adult supervision.
  - Do not attempt or allow somersaults. Landing on the head or neck can cause serious injury, paralysis, or death, even when landing in the middle of the mat.
  - Do not allow more than one person on the trampoline. Use by more than one person at the same time increases the chance of injury.
- 

Before you start to assemble.....	1-2
Trampoline Parts List.....	3
Assembly and Installation Instructions.....	4-11
Product Warranty.....	12-13

## **WARNING**

Carefully read and understand all of the instructions and warnings in this manual before assembling and using this product. It is the responsibility of the owner of this trampoline to ensure that all users of this product are fully informed on the proper use and the inherent risks of jumping on a trampoline. Failure to do so can result in serious injury or death.

### **Before you start to assemble...**

- Check the package and make sure you have all of the parts listed in the Parts List section of this user manual. IF ANY PARTS ARE MISSING, please call the Customer Service number listed on the cover page for assistance.
- Do not install or use the product if any parts are missing or damaged. Store in a safe place until ready to install.
- Make sure that you have plenty of space and a clean dry area suitable for the assembly of this trampoline. **IT IS ESSENTIAL THAT THE INTENDED SITE FOR THIS TRAMPOLINE IS COMPLETELY FLAT AND LEVEL.** Adequate overhead clearance is essential. A minimum of 8 meters from ground level is recommended. Provide clearance for wires, tree limbs, and other possible hazards. Always ensure the trampoline is on level ground with a minimum of 2 meters clear space from any structure or obstruction. If the ground is uneven, this could cause movement in the frame and stress on the joined sections of the frame that could damage the trampoline and/or can cause serious injury.
- Warning. The trampoline shall be assembled by two adults in accordance with the assembly instruction and thereafter checked before the first use.
- Never modify the construction or the design of the product. Do not use any unauthorised Sportspower parts with this trampoline.
- This pack may contain small parts and is not suitable for children under three (3) years of age to be nearby during assembly. Small parts. Choking hazard.
- **IMPORTANT:** Save this manual for future reference.

### **Care and Maintenance**













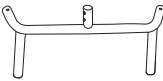

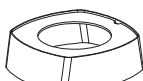
- The trampoline must be inspected prior to every use. The legs should be locked securely into place. If any part becomes damaged or worn, please stop using the trampoline immediately until this part is replaced with authorized Sportspower parts.
- If you see any signs of stretched or damaged springs, do not use the trampoline until replacement springs are properly installed. Please contact our customer service representatives to order original Sportspower replacement parts.
- Please do not use unauthorized Sportspower parts to assemble the trampoline. This may damage the integrity of the product and can cause injuries during use.
- Inspect the trampoline before each use and replace any worn, defective or missing parts. The following conditions could represent potential hazards:
  - Deterioration in the stitching or fabric of the mat, enclosure netting or frame padding
  - Bent or broken support system (frame)
  - Sharp protrusions on the support (frame) or suspension system

## Use Instructions:

- Always use the product in a well-lit area. Do not use without lighting during dawn, dusk or in complete darkness!
- The trampoline must be placed on a surface that is **COMPLETELY FLAT AND LEVEL**. If the ground is uneven, this could cause movement in the frame and could cause stress on the joined sections of the frame that could damage the trampoline and/or can cause serious injury.
- DO NOT install or position this trampoline on a hard surface such as concrete, tarmac or paving. Suitable surfaces are grass, sand or a play area covered with an appropriate depth of play bark material.
- Maintain clear space on all sides of the product. Make sure that there are no hazardous objects above, below or near the trampoline. Such objects include walls, fences, tree limbs/trunks, electrical power wiring, rocks, sprinkler heads or other recreational objects (i.e. swing sets, swimming pools). Children can be seriously injured colliding into such obstacles.
- Warning. Do not use in strong wind conditions and secure the trampoline. The product must not be used in windy conditions as wind can cause unexpected movement of the product. Wind can cause the trampoline to be lifted off the ground and become airborne. Damage from wind or other severe weather is not covered by the manufacturer's warranty.
- Children must always be supervised while they are playing on the trampoline and must be instructed not to use the trampoline in an inappropriate or hazardous manner. Take precautions to prevent access to the trampoline by children when there is no adult supervision.
- Restrict access to the trampoline by any unauthorized users without your consent.
- Trampolines are rebounding devices, which propel the user to unaccustomed heights, and into a variety of body movements. Rebounding off of the trampoline, striking the frame or springs, or improperly landing on the trampoline mat may cause serious injury.
- Always start and maintain your jump at the center of the trampoline mat in order to reduce the risk of landing on the frame or springs or falling off the trampoline.
- Avoid bouncing too high. Stay low until you can control your bounce and land consistently in the middle of the trampoline mat.
- Ensure the trampoline frame and springs are fully covered by the frame pad to avoid any direct contact with metal parts.
- Do not stand or jump on the springs while using the trampoline. The springs are not designed to support such stress and weight. This can result in serious injuries and/or product damage. If you see any signs of stretched or damaged springs, do not use the trampoline until replacement springs are properly installed. Please contact our customer service representatives to order original Sportspower replacement parts.
- Warning. Do not exit by a jump. Jumping off the trampoline to the ground or any other surface may result in injury. Smaller children may need assistance getting up onto or down from the trampoline. Mounting and dismounting properly should be followed as a strict rule. Users should climb onto the trampoline by placing their hands on the frame and stepping or rolling up onto the frame, across the springs and onto the mat. Do not step directly on the frame pad or grasp the frame pad when mounting or dismounting the trampoline. To dismount, jumpers should walk to the side of the mat, bend over and place their hands on the frame, then step from the mat to the ground. Users should always place their hands on the frame while mounting or dismounting.
- Do NOT use the trampoline as a springboard to jump onto other objects.
- Remove all objects not designed for use with the trampoline from the trampoline before use. Do not let children take toys or other items onto the trampoline.
- Warning. Always jump in the middle of the mat. Do not jump or step onto the frame pad as it was not designed to support the weight of a person.
- Do not use the trampoline while holding or wearing any type of sharp or pointed objects such as jewelry, watches, rings, eyewear and necklaces before using this product. This will prevent the jewelry from tearing the mat or getting caught in the enclosure netting.
- Never wear footwear (e.g. shoes) when using the trampoline.
- Warning. Do not use the mat when it is wet.
- Warning. Do not eat while jumping.
- Warning. Limited the time of continuous usage (make regular stops).
- Check all nuts and bolts for tightness and tighter when required.
- Check that all spring-loaded(pit pin) joints are still intact and cannot become dislodged during play
- Check all coverings and sharp edges and replace when required
- Place the trampoline on a level surface at least 2m from any structure or obstruction

In certain countries during winter period, the snow load and the very low temperature can damage the trampoline. It is recommended to remove the snow and store the mat and the enclosure indoor

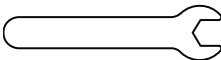
## Trampoline Parts List

Key Number	Part Picture	Description	Quantity
1		Arch top rail	2
2		"U" Top Rail with Leg Post	1
3		"U" Top Rail with Leg Post	1
4		"T" Handle Bar	1
5		Mat	1
6		Pad	1
7		Elastic Cord	1
8		HOOK	1
9		Plastic Tube	1
10		Leg Cap	4
A		Bolt(M6X38mm)	6
B		Arc Washer(Φ6.5 x Φ13)	12
C		Spring Washer(Φ6.5 x Φ13)	6
D		Cap Nut(M6)	6
E		Spanner(M6)	1
F		Allen Key(4mm)	1

For faulty or missing parts please contact customer services: Call (+44) 0330 0904 420,  
Email [warranty@sportspower.biz](mailto:warranty@sportspower.biz)

STEP 1

Remove all parts from the packaging and lay the frame out in a large open space.

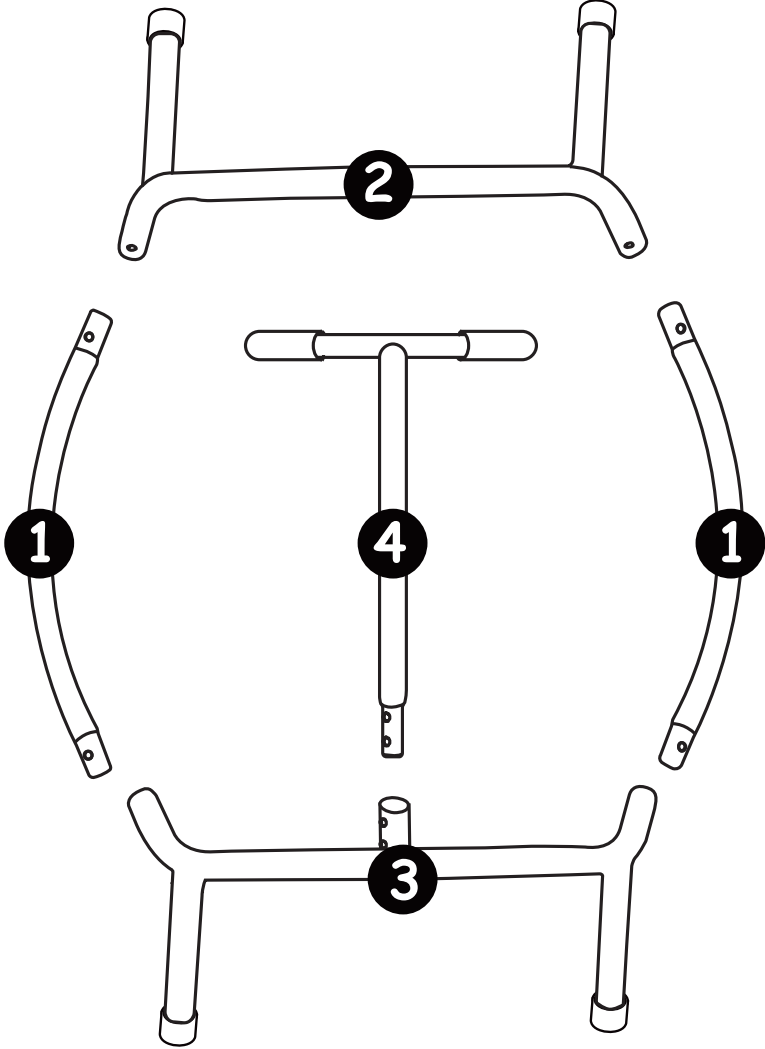

**STEP 2**

Attach all legs as shown below.

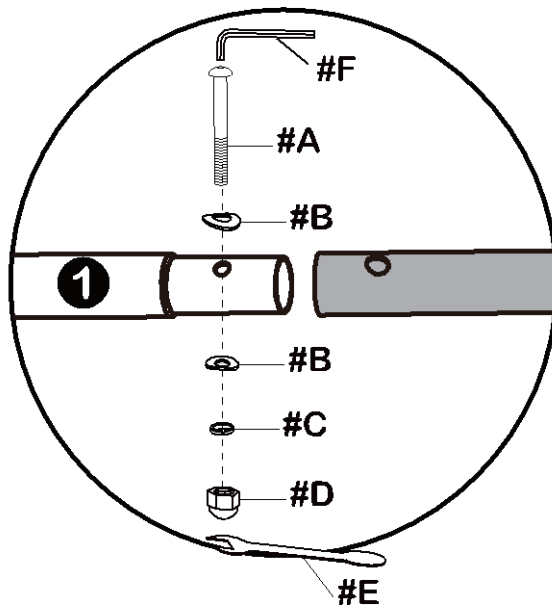
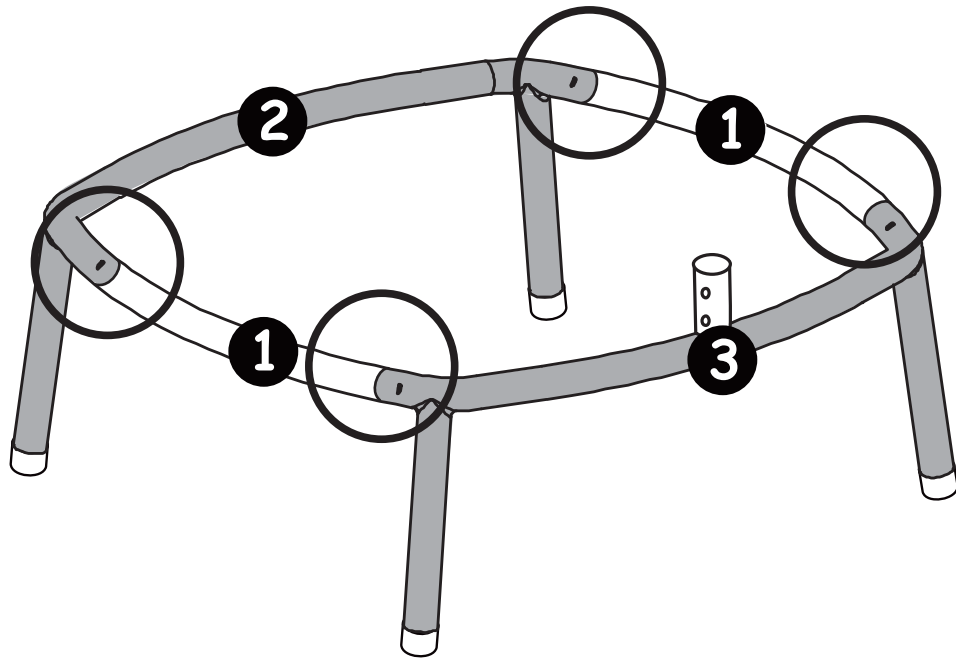



**STEP 3**

**Attach one hook (9) end of a leg as shown.**

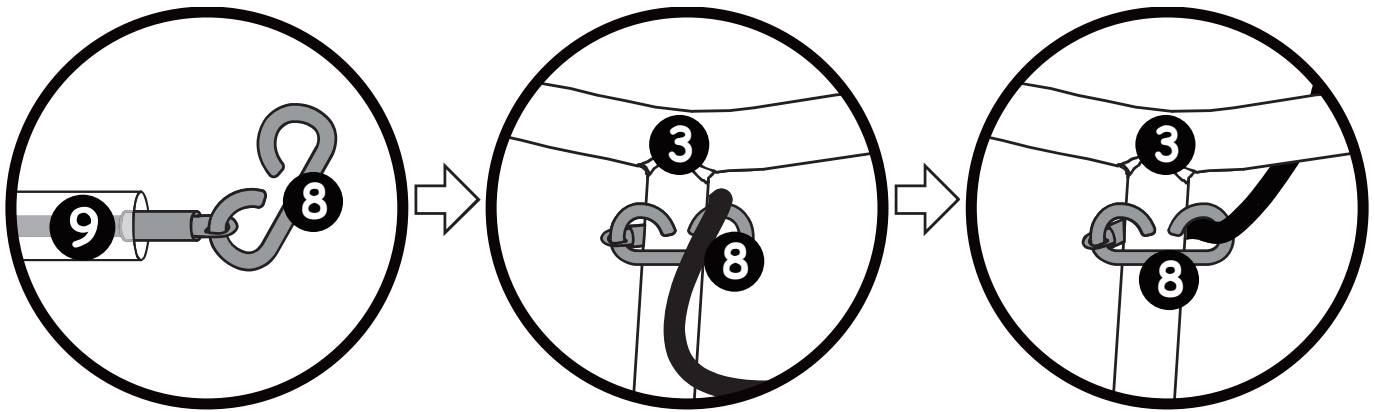
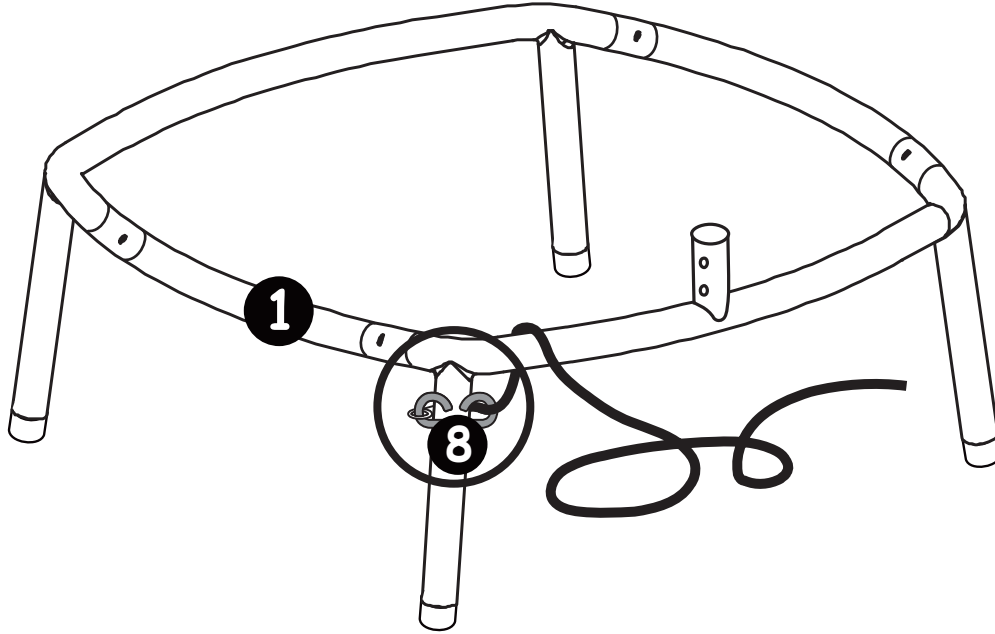

**STEP 4**

Wrap the elastic cord (8), ensuring that the length of the elastic cord is equal on both sides. Thread the elastic cord all the way around the trampoline as shown.

Once the elastic cord has been fully wrapped around the mat and frame, attach the plastic tube (10) and the hook (9) to the ends of the elastic cord as shown.

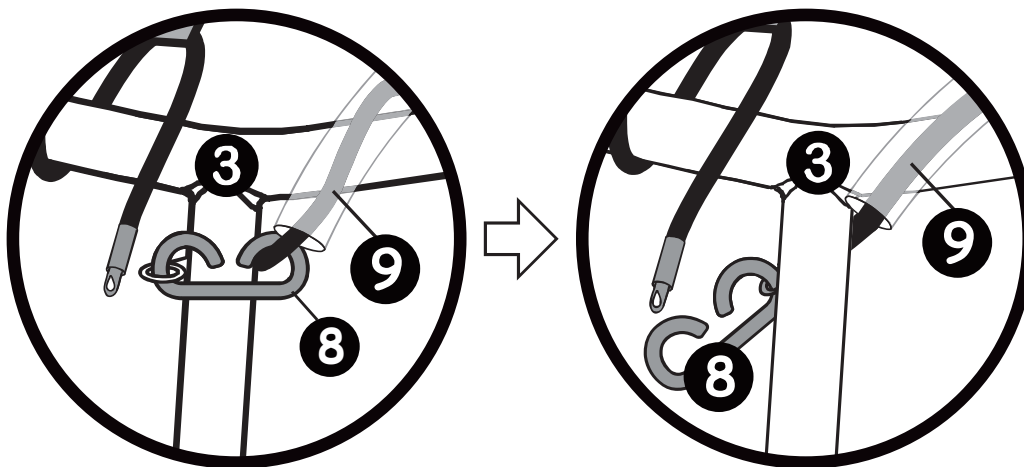
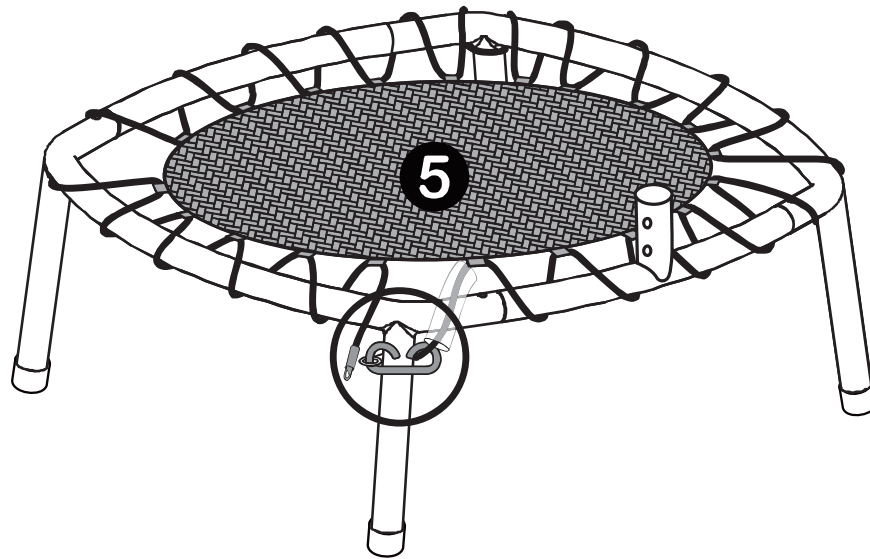

**STEP 5**

Hook the elastic ends together and slide the plastic tube (10) over the hook to cover it completely. Please take care when hooking the elastic cord around the final leg frame as the tension of the elastic cord at this point will be high.

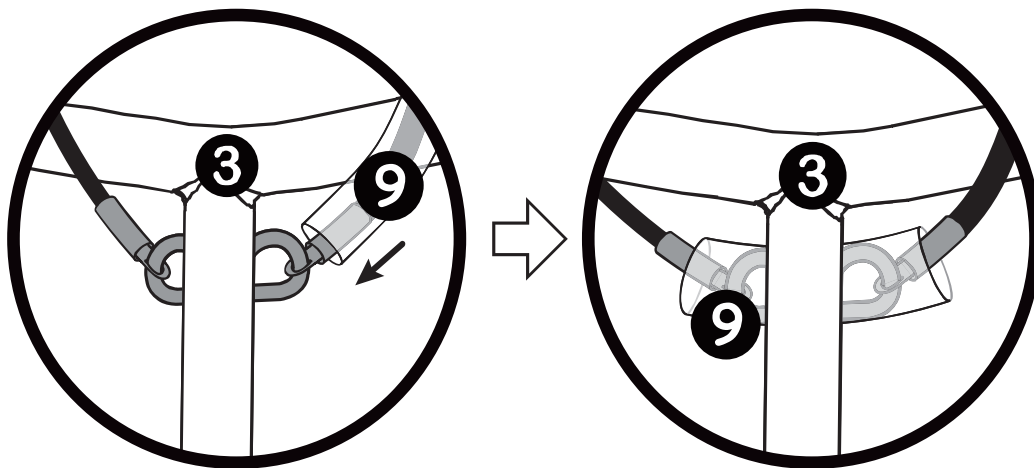
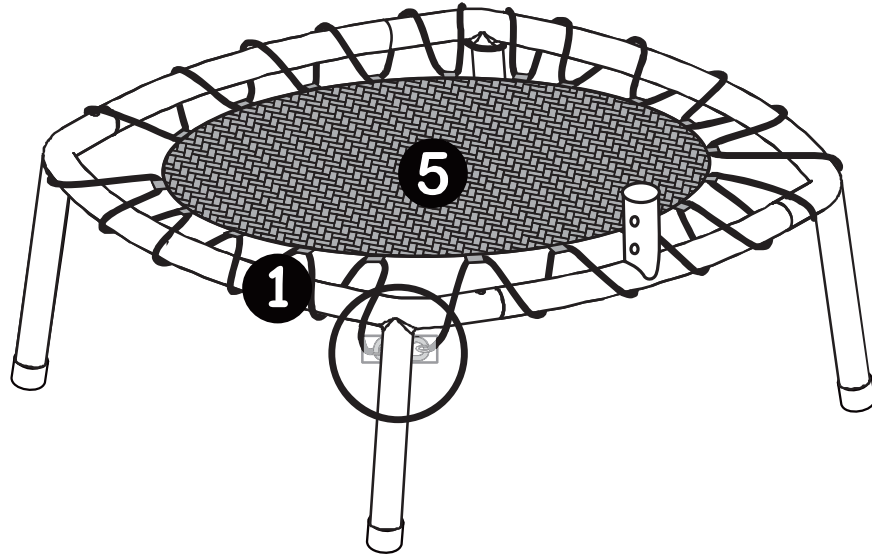

**STEP 6**

Place mat onto the assembled leg frame.

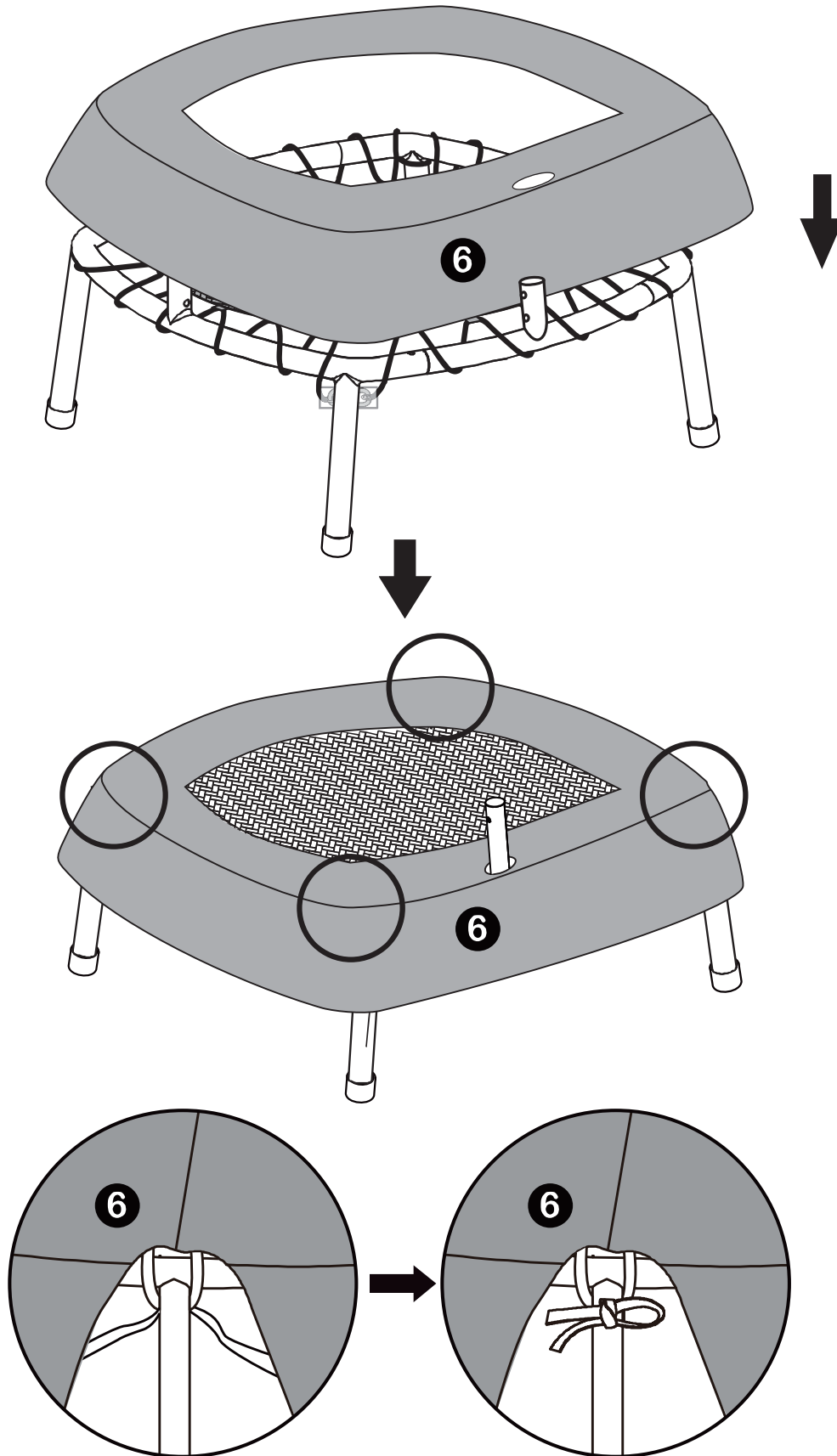

**STEP 7**

Attach "T" Handle Bar (4) to "U" Top Rail With Leg Post (3) as shown.

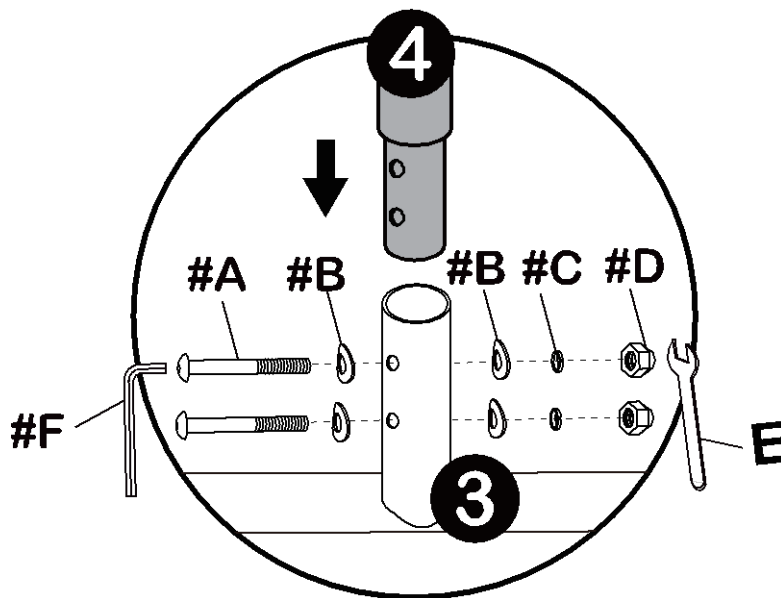
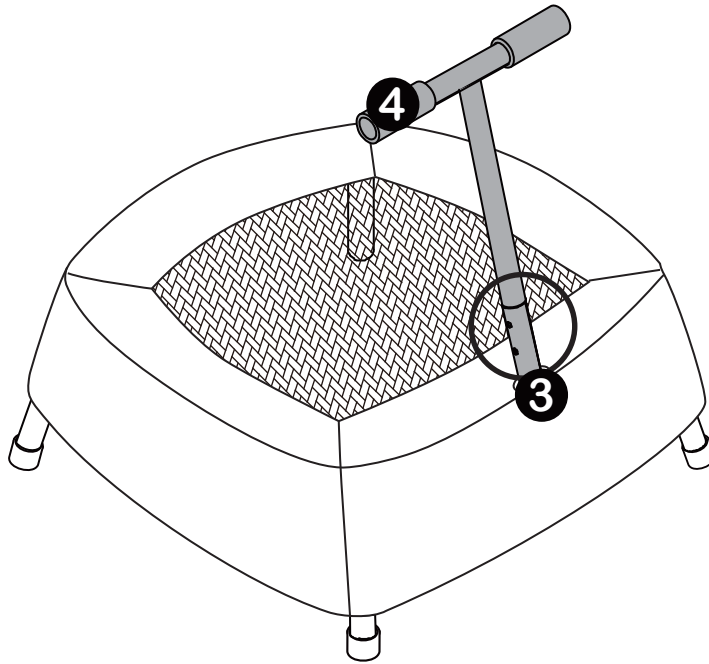

**STEP 8**

**Finished Product**

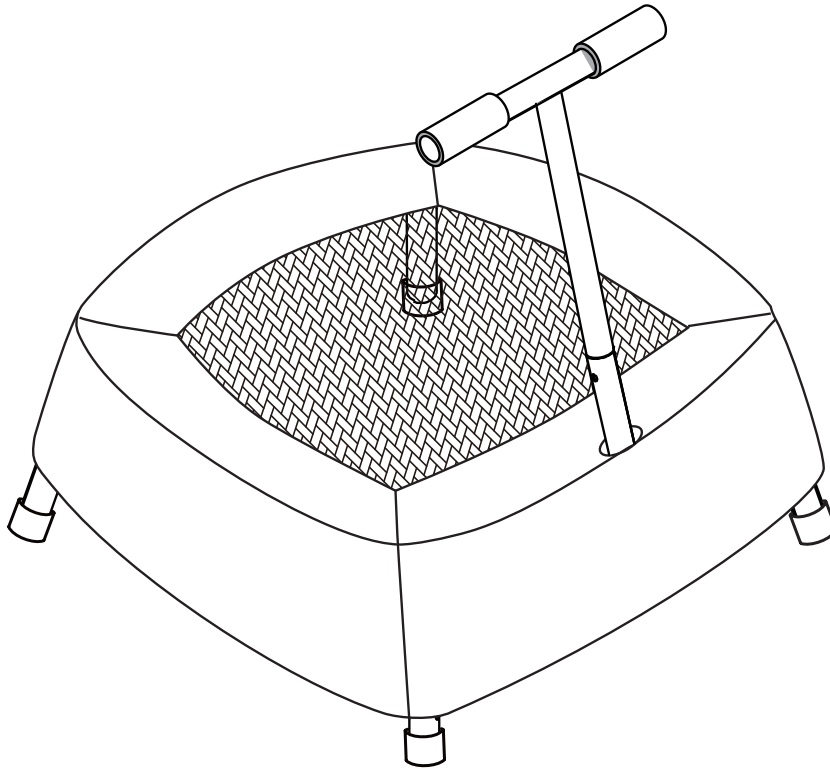

**Note: Re-check all the screws to make sure they are securely fastened before use.**

## Product Warranty

Sportspower Ltd warrants its products to be free from defects in material and workmanship under normal use and service conditions for ninety (90) days after the date of purchase. The frame on trampolines is warranted for ninety (90) days after the date of purchase.

All warranty coverage extends only to the original purchaser of the product and is not assignable or transferable. The original store or online purchase receipt must be kept as proof of purchase in order for the warranty to be valid. These documents must be presented in the event of making a warranty claim.

During the warranty period, Sportspower will provide repair or replacement of defective equipment or parts thereof covered by the warranty. Any handling, transportation, delivery and other incidental charges in respect of the servicing of the equipment shall be borne by the Purchaser. If the product includes a number of accessories, only the defective part or accessory will be replaced.

The warranty will become void if any defects or damages are associated with the use of unauthorised replacement parts. All replacement parts must be obtained from Sportspower authorised agents.

All decisions made by Sportspower made in respect of the servicing of the equipment (including repairs, replacements or issues relating to defects of workmanship or materials) shall be conclusive and the Purchaser agrees to be bound by such decisions. Any defective equipment or part thereof replaced shall become the property of Sportspower.

In the event of a product or accessory being replaced during the guarantee, the guarantee on the replacement will expire at the original date, i.e. 90 days from the original purchase date.

This warranty excludes defects caused by the product not being used in accordance with instructions, accidental damage, misuse or being tampered with by unauthorised persons.

The Sportspower Limited Warranty does not cover:

- a) Products used for commercial or rental purposes.
- b) Loss or damage to product due to:
  - i. Abuse, repairs and/or tampering by any person other than the authorised personnel of Sportspower
  - ii. Negligence and/or misuse (including foreign objects, accidents, improper storage, exposure to sun/moisture, excessive temperature, sand, dust, dirt, other pollution or other environmental conditions and failure to follow precautions or proper operating instructions stated in the User's Manual such as improper installations)
  - iii. Fire, flood, lightning strike, wind storm or other acts of God
  - iv. Freight or improper transport damages, and
  - v. Improper usage (including use by underage, overweight or excessive number of users permitted as stated in the User's Manual).
- c) Defects, damages or accidents due to the malfunction, connection to or use of non-Sportspower or unauthorized parts. In such event, Sportspower reserves the right to cancel the Limited Warranty coverage immediately.

To the extent allowed by the applicable local law, the remedies in the Limited Warranty are the Purchaser's sole and exclusive remedies.

**PRODUCT WARRANTY**

SPORTSPOWER IS NOT RESPONSIBLE OR LIABLE FOR INDIRECT, SPECIAL OR CONSEQUENTIAL DAMAGES ARISING OUT OF OR IN CONNECTION WITH THE USE OR PERFORMANCE OF THE PRODUCT OR OTHER DAMAGES WITH RESPECT TO ANY ECONOMIC LOSS, LOSS OF PROPERTY, LOSS OF REVENUE OR PROFITS, LOSS OF ENJOYMENT OR USE, COST OF REMOVAL, INSTALLATION OR OTHER CONSEQUENTIAL DAMAGES. SOME STATES DO NOT ALLOW THE EXCLUSION OR LIMITATION OF INCIDENTAL OR CONSEQUENTIAL DAMAGES. ACCORDINGLY, THE ABOVE LIMITATION MAY NOT APPLY TO YOU.

PLEASE NOTE: ANY REPAIRS OR REPLACEMENTS MUST BE MADE USING AUTHORIZED SPORTSPOWER PARTS IN ORDER FOR THIS WARRANTY TO BE VALID.

**DO NOT RETURN PRODUCT TO THE STORE. PLEASE CONTACT OUR CUSTOMER SERVICE FOR PARTS OR ASSEMBLY INSTRUCTIONS. STORES ARE NOT EQUIPPED TO PROVIDE CUSTOMER SERVICE FOR THIS PRODUCT.**

**CUSTOMER SERVICE/ SPARE PARTS -(+44 ) 0330 0904 420  
by email [warranty@sportspower.biz](mailto:warranty@sportspower.biz),  
or visit [www.sportspowerfit4kids.com](http://www.sportspowerfit4kids.com)**

**Importer's name Retail Marketing Service GmbH**

**Importer's address Besselstr. 25 68219 Mannheim Germany**

**Importer's name Geemac Sales & Marketing Ltd**

**Importer's address 4 Summerhouse Place, Summerhouse Road, Moulton Park  
Industrial Estate Northampton, United Kingdom, NN3 6GL.**

Sportspower Ltd.

20/F, Parkview Centre, 7 Lau Li Street, Causeway Bay, Hong Kong  
[www.sportspowerltd.net](http://www.sportspowerltd.net)